

REVISIONS		DATE	APPROVED
REV	DESCRIPTION		
1	-	-	-

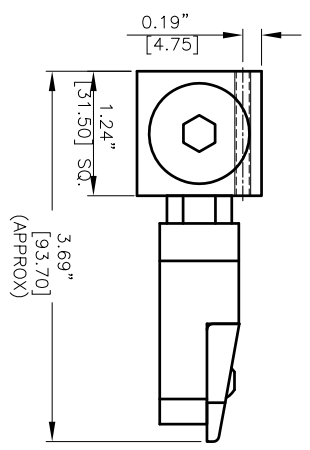
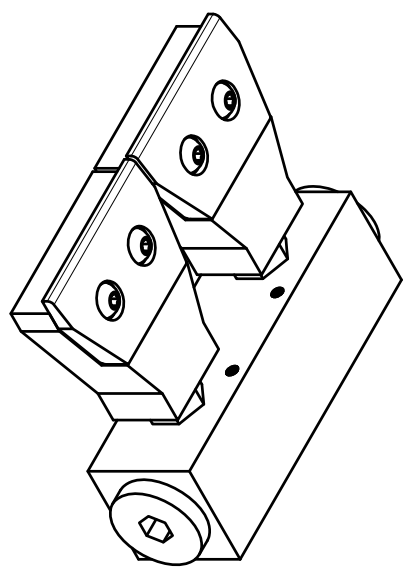
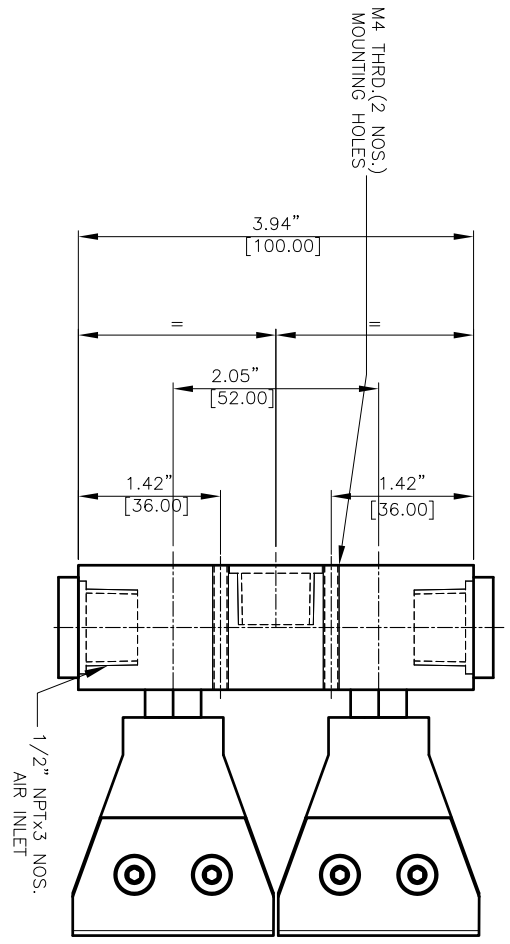

REVISIONS	DATE	APPROVED
1	-	-

REQUIREMENTS - FINISHES 1. DIMENSIONS AND TOLERANCES IN ACCORDANCE WITH ASME Y14.5 (1982) 2. MACHINE FINISH 125 MICRO INCH RMS & BREAK SHARP CORNERS .005 TO .015 3. ANGLES = ± 1/2° 4. HOLES IN ACCORDANCE WITH AND 10397	CONTRACT NUMBER CLIENT CONTRACTOR DRAWN CHECKED DATE APPROVED Q.A.	MANUFACTURING MATERIALS FINISHES ELECTRICAL	SIZE DATE CODE DIM NO CDR NO HFRMAN-24-FJ	RELDATE REV SHEET 1 OF 1
---	--	---	--	---------------------------------------

FINISH AL/SS304/SS316L	TEMPERATURE PROTECTION 	REVISIONS 1 2 3 4 5	REVISIONS 1 2 3 4 5	REVISIONS 1 2 3 4 5	REVISIONS 1 2 3 4 5
----------------------------------	-----------------------------------	---	---	---	---

NEX FLOW AIR PRODUCTS CORP.
 10520 YONCE STREET, UNIT 259-220 RICHMOND HILL, ON L4C 3C7
 TEL: (416) 410-1313 & FAX: (416) 410-1806 www.nier-flow.com

2 PORT HIGH FLOW MANIFOLD
 WITH 47011 FLATJET